



USB-2068-18

USB I/O Module with 10-ch DI and 8-ch Signal Relay

Features

- 10-ch digital input and 8-ch relay output
- Dry Contact and Wet Contact Selectable via Wire Connections
- All Digital Input Channels can be used as 32-bit Counters
- Form C Relay Output
- 8 kV ESD protection
- Wide Operating Temperature Range
- 3000 VDC Intra-Module Isolation
- USB 2.0 Full-Speed (12Mbps)
- USB Bus Powered
- Lockable USB cable
- Driver Free



Introduction

The USB-2068-18 is an 8-ch Form C relay output and 10-ch digital input module with the USB interface. All digital input channels can be used as 32-bit counters. In addition, the digital input channels can be selected as sink/source type and dry/wet contact via wire connections. There are also options for configuring power-on and safe values. 8 kV ESD protection(for all channels) and 3750 VDC intra-module isolation(for digital input channels) are also provided to enhance noise protection capabilities in industrial environments. Compare with traditional PC I/O card, it is waste of time to open chassis and configure I/O board. In ICP DAS USB I/O, you will enjoy the simply controlling I/O in the efficient way. ICP DAS USB I/O equips USB bus powered feature, one cable to access I/O and provide power without additional power wiring.

The USB I/O utility can help users to configure and control USB-2068-18 quickly and easily without programming; In addition, we also provide the friendly API library and demos for users to develop own USB application with various application development tools (VB/C++/C#.NET/VB.NET). Therefore, the USB-2068-18 is the perfect way to add control capability to any USB capable computer.

Software

USB I/O Utility

USB I/O Utility provides a simple way to easily test and instant acquire data for all ICP DAS USB I/O series modules without programming.

- Automatically scan all ICP DAS USB I/O modules
- Easily and quickly configure and test USB I/O modules
- Completely and precisely log I/O data for analysis

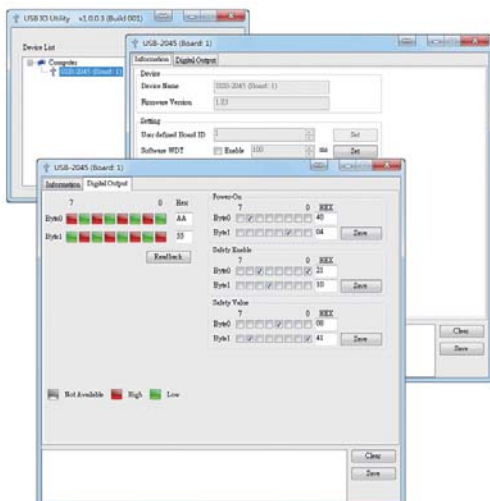

VB/C++/C#.NET/VB.NET SDK

ICP DAS provides a SDK for USB I/O modules to help user to develop own project easily and quickly. The SDK can be supported in VB/C++/C#.NET/VB.NET to fulfill project development.

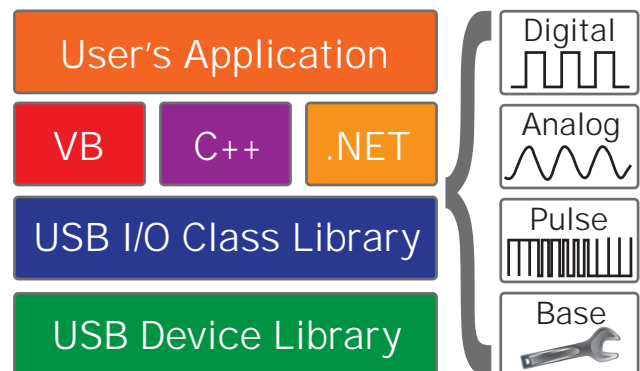

Applications

- Automation
- Measurement and testing
- Laboratory research

System Specifications

USB	
Specification	USB 2.0 Full-Speed (12Mbps)
CPU Module	
Watchdog Timer	1 Hardware watchdog (1.6 second) 1 Software watchdog (Programmable)
Isolation	
Intra-module Isolation	3000 VDC
EMS Protection	
ESD (IEC 61000-4-2)	±8 kV contact for each terminal ±16 kV air for random point
LED Indicators	
Status	3 x Power and Communication 12 x Power Relay
Power	
Consumption	2.3 W
Mechanical	
Dimensions (mm)	31 x 147 x 126 (W x L x H)
Environmental	
Operating Temperature	-25 ~ +75 °C
Storage Temperature	-40 ~ +85 °C
Humidity	10 ~ 95% RH, Non-condensing

Pin Assignments

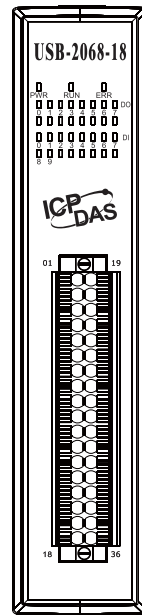

Pin Assignment	Terminal No.	Pin Assignment	
NC6	01	19	NC0
COM6	02	20	COM0
NO6	03	21	NO0
NC7	04	22	NC1
COM7	05	23	COM1
NO7	06	24	NO1
D.GND	07	25	NC2
DI0	08	26	COM2
DI1	09	27	NO2
DI2	10	28	NC3
DI3	11	29	COM3
DI4	12	30	NO3
DI5	13	31	NC4
DI6	14	32	COM4
DI7	15	33	NO4
DI8	16	34	NC5
DI9	17	35	COM5
D.COM	18	36	NO5

I/O Specifications

Digital Input/Counter	
Channels	10
Type	Dry Contact, Close to GND Wet Contact, Sink/Source
ON Voltage Level	+10 ~ 50 VDC
OFF Voltage Level	+4 VDC Max.
Max. Counts	4294967295 (32-bit)
Frequency	500 Hz
Min. Pulse Width	1 ms
Input Impedance	10 KΩ
Overvoltage Protection	70 VDC
Relay Output	
Channels	8 Form C
Contact Rating	0.25 A @ 250 VAC 0.24 A @ 220 VAC
Electrical Endurance	2 x 10 ⁵ ops (at 30 V / 2 A)
Mechanical Endurance	1 x 10 ⁸ ops
Power on Value	Yes, Programmable
Safe Value	Yes, Programmable

Wire Connections

Input	ON	OFF
Dry Contact		
Wet Contact (Sink)		
Wet Contact (Source)		
Output	ON State LED ON Readback as 1	OFF State LED OFF Readback as 0
From C Relay Contact		

Dimensions (Units: mm)

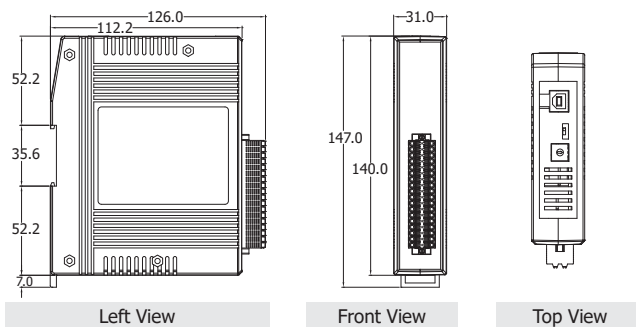

Ordering Information

USB-2068-18 CR	USB I/O Module with 10-ch DI (Dry, Wet) and 8-ch Signal Relay (RoHS)
-----------------------	--